

# new products

# WESCO®



**Wesco Industrial Products brings you fine quality material handling equipment and excellent customer service.**



# Wesco® Ergonomic Drum Handlers

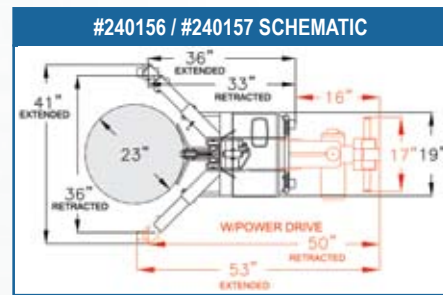
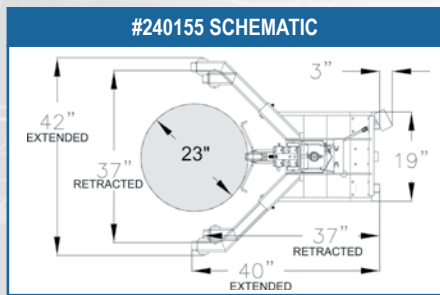
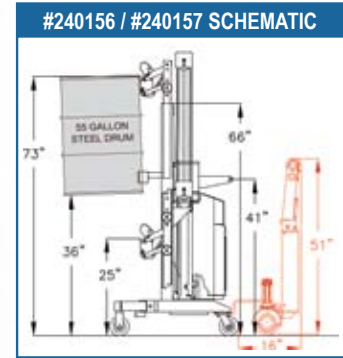
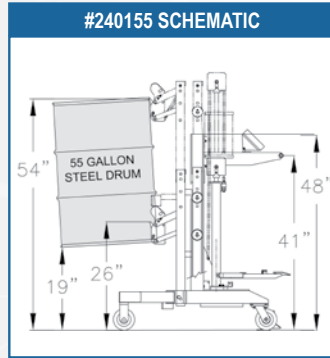
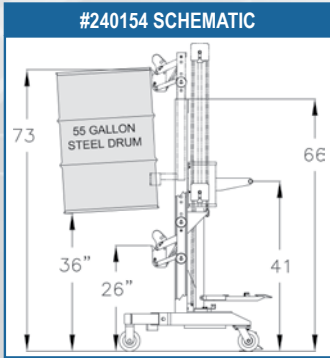

**High Reach Model**



**Scale Model - Accuracy ± .5 lbs.**



**Power Lift**



**Power Lift & Drive**

- Ergonomic solution for lifting, transporting, weighing and placing drums on spill or standard pallets.
- Spring-loaded clamp holds any 3/16" or higher drum rim.
- (2) wheels and (2) swivel casters, 5" x 2" phenolic, and floor lock.
- Handles most 30, 55 or 85 gallon drums - Steel, Fiber and Poly.

- Works with most drums with locking rings.
- Operator does not need to touch drums to operate.
- Exclusive auto grip lock will not drop a drum.
- Up/Down remote on power units.
- Power drive travel speed 120'/min.

Part # Model #	240154 DM-1100-HR	240155 DM-1100-S	240156 DM-1100-PL	240157 DM-1100-PLD
Description	High Reach	Scale	Power Lift - High Reach	Power Lift & Drive - High Reach
Rise/Stroke	1"	1"	8.5" / sec. without load	8.5" / sec. without load
Legs Retracted Capacity	650 lbs	650 lbs	650 lbs	650 lbs
Legs Extended Capacity	1100 lbs	1100 lbs	1100 lbs	1100 lbs
Weight	376 lbs	356 lbs	531 lbs	691 lbs

*All Models with U.S. Patented Gator Grip U.S. Patent No. 6,619,905.*

# Stainless Steel Drum Dollies

- **Wesco's Stability Advantage.** By design, Wesco casters are mounted past the dolly and drum rim. Our casters are mounted further apart than standard designs with casters completely underneath the drum and closer together. The further the casters are apart the greater the stability.
- Welded 304 stainless steel dolly construction with reinforced outriggers.
- 304 stainless dollies are ideal for clean room, pharmaceutical, food and wash down applications.
- Models available for 30, 55, and 85 gallon drums.
- Three caster set options:  
HRZ: zinc plated swivel rig with 3" hard rubber wheel & zinc plated hardware

- \*HRSS: 304 stainless steel swivel rig with 3" hard rubber wheel & stainless hardware
- \*PPSS: 304 stainless steel swivel rig with 3" white polypropylene wheel and stainless hardware.
- \*Suitable for wash down applications.*



AVAILABLE SEPT.  
2012

**SS5-PPSS**  
*All stainless rigs with  
3" polypropylene  
wheels*

ASSEMBLED OVERALL  
DIMENSIONS SS3

w: 24"  
h: 6"  
d: 24"

ASSEMBLED OVERALL  
DIMENSIONS SS5

w: 28.5"  
h: 6"  
d: 28.5"

ASSEMBLED OVERALL  
DIMENSIONS SS8

w: 31.5"  
h: 6"  
d: 31.5"

Part # Model #	240192 SS3-HRZ	240193 SS3-HRSS	240194 SS3-PPSS	240195 SS5-HRZ	240196 SS5-HRSS	240197 SS5-PPSS	240198 SS8-HRZ	240199 SS8-HRSS	240200 SS8-PPSS
Capacity	900 lbs	900 lbs	1,000 lbs	900 lbs	900 lbs	1,000 lbs	900 lbs	900 lbs	1,000 lbs
I.D.	19"	19"	19"	24"	24"	24"	27"	27"	27"
Drum Size	30 gal	30 gal	30 gal	55 gal	55 gal	55 gal	85 gal	85 gal	85 gal
Caster Rig	Zinc plate 4 swivel	Stainless 4 swivel	Stainless 4 swivel	Zinc plate 4 swivel	Stainless 4 swivel	Stainless 4 swivel	Zinc plate 4 swivel	Stainless 4 swivel	Stainless 4 swivel
3" Caster Wheel	Hard Rubber	Hard Rubber	White Polypropylene	Hard Rubber	Hard Rubber	White Polypropylene	Hard Rubber	Hard Rubber	White Polypropylene
Dolly Material	304 Stainless	304 Stainless	304 Stainless	304 Stainless	304 Stainless	304 Stainless	304 Stainless	304 Stainless	304 Stainless
Weight	19 lbs	20 lbs	18 lbs	23 lbs	24 lbs	22 lbs	27 lbs	28 lbs	26 lbs

# Spartan Aluminum Shelf Carts

- Built from standard Spartan Convertible Truck frames with 18" cast noseplate.
- Lightweight aluminum truck and shelves.
- Two sizes - Jr. and Sr.
- Shelves made in **USA**. Maximum shelf capacity is 200 lbs with evenly distributed load.
- One carpeted shelf standard, optional 2nd carpeted shelf available.
- Strap and ratchet assembly to secure shelves for knock down and transport. 5' long ratchet strap.
- Spartan Platform deck options fit shelf trucks; see Spartan Options #220800 and 220288.
- Non-marking 5" x 1.25" polyethylene swivel casters.
- Wheels: PE 10" pneumatic or SR 10" solid rubber.
- Shelf inside dimensions: JR - 36.5"L x 17.75"W x 1.375"D.  
SR - 49"L x 17.75"W x 1.375"D.



# Universal Drum Lifter

- Design allows for the loading of drums into overpacks.
- Works on open and closed head drums.
- For use with standard steel or poly drums with at least a 3/16" chime.
- Lifting arms are adjustable to work with most 55 or 30 gallon drums.
- Three-point contact of the lifting arms prevents or minimizes deformation of the drum and provides more secure lifting.



SPARTAN JR  
OVERALL DIMENSIONS

w: 47"      47"      18.25"  
h: 41.5"    41.5"    40.625"  
d: 19"      19"      2.75"

SPARTAN SR.  
OVERALL DIMENSIONS

w: 57"      57"      18.25"  
h: 45.5"    45.5"    53.5"  
d: 19"      19"      2.75"

Part # Model #	220126 S-JR-SHELF-PE	220142 S-JR-SHELF-SR	220128 JR-O-SHELF	220127 S-SR-SHELF-PE	220143 S-SR-SHELF-SR	220129 SR-O-SHELF
Capacity 2 Wheel 4 Wheel	200 lbs Per Shelf *	200 lbs Per Shelf *	200 lbs Per Shelf *	200 lbs Per Shelf *	200 lbs Per Shelf *	200 lbs Per Shelf *
Description	Shelf Truck	Shelf Truck	Optional Shelf	Shelf Truck	Shelf Truck	Optional Shelf
Wheel	PE	SR	NA	PE	SR	NA
Caster	5" x 1.25"	5" x 1.25"	5" x 1.25"	5" x 1.25"	5" x 1.25"	5" x 1.25"
Weight	54 lbs	64 lbs	10 lbs	60.5 lbs	70.5 lbs	12.5 lbs

OVERALL  
DIMENSIONS

w: 29.5"  
h: 5.5"  
d: 29.5"

Part # Model #	240062 UDL
Capacity	1,000 lbs
Weight	16.5lbs

\* Capacity 200 lbs per shelf with an evenly distributed load.

# Stair Climbing Hand Trucks

Contact Wesco Customer Service to get full details to configure your Liftkar SAL stair climbing truck (frame style, toe plate, wheel type, capacity, accessories).

- Choose from 3 different capacities, 2 different wheels, 7 toe plates and a variety of accessories to create your stair climbing hand truck (see catalog or contact Wesco for specifics).
- Dual speed control on all models to fit your application.
- Quick-change battery, charger and 56" cargo strap included.
- Pivoting and fixed handle configurations available to handle a wide variety of cargo.
- Choose from the long list of options to maximize the utility of your Liftkar.
- 240 to 375 lb. capacity on SAL models.
- Climbs up to 48 steps per minute.
- 1 year warranty on parts against defects in materials and workmanship.
- 6 month warranty on battery.

**LIFTKAR<sup>®</sup> SAL**



**Ergo**

The ergo handle is the most popular all-purpose model with 3-handle gripping points providing proper balance for a variety of loads. (Shown with "G" Toe Plate.)

**Uni**

Ideal for tall, easily balanced loads. 2-handle gripping points. (Shown with "G" Toe Plate.)



**Fold**

This model allows user to place handle in optimum position. Ideal for short, heavy loads that require truck to be tilted to an extreme angle for proper balance. (Shown with "G" Toe Plate.)



**Fold L**

Similar to fold but has a longer frame and shorter handle. This makes it ideal for loads that require less tilt for proper balance than the Fold provides. (Shown with "G" Toe Plate.)



See the **LIFTKAR** video on our website!  
[www.wescomfg.com](http://www.wescomfg.com)

**ALSO, see back page for Power LiftKar HD information.**

## CP3 Pallet Truck

- 2 year pump warranty.
- 3 mm thick forks.
- Adjustable fork connecting rods.
- Overload bypass.
- Rubber coated handle.
- 7" moldon polyurethane steering wheels.
- 3" moldon polyurethane load wheels.
- Entry and Exit Rollers.
- 210° steering.



273448

## Long Fork Pallet Truck

- 2 year pump warranty.
- Pump, load wheels and steering wheels same as CPI model.
- Overload bypass.
- Rubber coated handle.
- 7" moldon polyurethane steering wheels.
- 3" moldon polyurethane load wheels.
- 70" and 78" long forks available.
- 78" forks handle 2 standard size pallets.

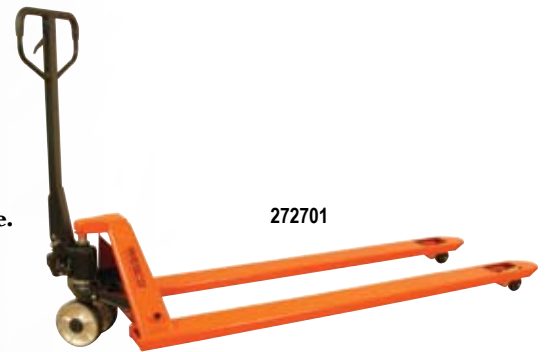

272701

Part #	273453	273454	273448	272701	273519
Model #	CP3	CP3	CP3	PT70	PT78
Capacity	5,500 lbs	5,500 lbs	5,500 lbs	4,400 lbs	4,400 lbs
W-1 x L-1	21" x 36"	21" x 48"	27" x 48"	27" x 70"	27" x 78"
W-2	6"	6"	6"	6"	6"
L-2	51"	63"	63"	86"	86"
WHL-1 / WHL-2	7" / 3"	7" / 3"	7" / 3"	7" / 3"	7" / 3"
WH-1 / H-2 / H-3	48.25" / 2.9" / 7.25"	48.25" / 2.9" / 7.25"	48.25" / 2.9" / 7.25"	49" / 3" / 8"	49" / 3" / 8"
Weight	166 lbs	187 lbs	194 lbs	308 lbs	320 lbs

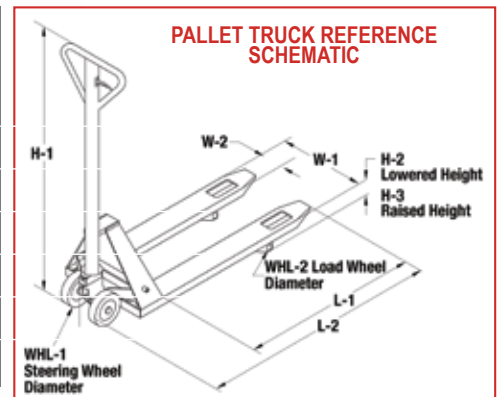

# Heavy Duty Vending Trucks

## WHEEL LOCK FEATURE STANDARD:

- Front wheels have wheel locks to allow truck to be placed in upright position without the danger of the truck rolling away from operator. Wheel lock is activated by a conveniently located lever at top of truck.
- In transport position load rests on (2) 10" aluminum or the poly hub moldon rubber wheels and (2) 5" poly hub moldon rubber front wheels.
- Rear main wheel design allows truck to be tilted back to clear doorways. Especially useful with tall vending machines or other tall cargo.
- Available in 72" and 78" heights.
- 2 webbed cargo belts with eccentric tighteners for maximum load security.
- Constructed of heavy duty 1" diameter steel tubing.
- Noseplate - 9" D x 24" W x .25" thick.
- Tilt back at 49° angle.



230072



A Wesco Unique Design - Swivel Casters for Easy Mobility



230076

# Heavy Duty Auto-Rewind Appliance Truck with Swivel Casters

- Truck can be used in 2-wheel or 4-wheel mode.
- Dynamic lever activated fulcrum system – fulcrum point changes as truck is tilted to decrease break-over effort.
- Swivel caster carriage kickout for four wheel support, lever release.
- 10" poly hub main wheels, 6" rear swivel casters.
- Available in 72" and 78" heights.
- 2 webbed cargo belts with ratchet tighteners for maximum load security.
- Constructed of heavy duty 1" diameter steel tubing.
- Noseplate - 5" D x 24" W x .25" thick.

HEAVY DUTY VENDING TRUCK OVERALL DIMENSIONS

w: 24"	24"	24"	24"	27"	27"
h: 72"	72"	78"	78"	72"	78"
d: 20.25"	20.25"	20.25"	20.25"	17"	17"

AUTO-REWIND APPLIANCE TRUCK OVERALL DIMENSIONS

w: 27"	27"
h: 72"	78"
d: 16"	16"

Part #	230070	230071	230072	230073	230074	230075	230076	230077
Model #	HDVT-72-EC	HDVT-72	HDVT-78-EC	HDVT-78	HDSV-72	HDSV-78	WRV-MAX-72	WRV-MAX-78
Capacity	1,800 lbs	1,800 lbs	1,800 lbs	1,800 lbs	1,800 lbs	1,800 lbs	1,800 lbs	1,800 lbs
Ratchet	Eccentric	Auto Rewind	Eccentric	Auto Rewind	Auto Rewind	Auto Rewind	Auto rewind	Auto rewind
Belt	1 piece	2 piece w/clasp	1 piece	2 piece w/clasp	2 piece w/clasp	2 piece w/clasp	2 piece w/clasp	2 piece w/clasp
Wheel	10" x 2.5" Alum.	10" x 2.5" Alum.	10" x 2.5" Alum.	10" x 2.5" Alum.	10" x 2.5" Poly	10" x 2.5" Poly	10" x 2.5" Poly	10" x 2.5" Poly
Noseplate	21"W x 9"D	21"W x 9"D	21"W x 9"D	21"W x 9"D	24"W x 5"D	24"W x 5"D	24"W x 5"D	24"W x 5"D
Weight	137 lbs	137 lbs	142 lbs	142 lbs	126 lbs	129 lbs	120 lbs	130 lbs

# Deluxe Power Pallet Trucks

- 2 year warranty: DC motor drive, hydraulic pump, controllers and switches.
- 180-day parts warranty.
- Trucks sold complete with battery and charger.
- Ergonomic control handle with: throttle forward and reverse speeds, lift and lower controls, horn, belly reverse safety button, electromagnet disc brake with automatic dead-man feature when handle is released.
- Increased Amp hour rating over standard models.
- Curtis Electronic Controls.



Light Duty  
273445



Heavy Duty  
273446

Part #	273445	273446
Capacity	3,300 lbs	4,400 lbs
W-1 x L-1	25.5" x 48"	27" x 48"
W-2	6.25"	6.25"
L-2	65"	72"
WHL-1 / WHL-2	10" x 3.5" / 3" x 3.75"	9" x 3" / 3" x 3.75"
H-1 / H-2 / H-3	50" / 3" / 7.67"	50" / 3" / 7.67"
Battery	(2) 12V 80Ah	24V 210 Ah
Steering Angle	205°	180°
Weight	631 lbs	1,147 lbs

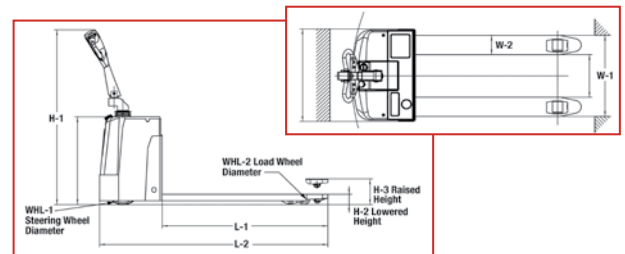

# Hand Winch Lifters

- Capacities: 350, 400 and 500 lbs.
- Aluminum and steel construction.
- 8" rear wheels and 2" front swivel casters are non-marking.
- Forks can be inverted for two different lift heights. Fork size: 4"W x 22.5"L x 1.75"H.
- Winch crank handle locks to secure carriage.

■ Three models:

**Fixed Base** used in narrow work spaces. Base legs: 13" inside width x 21.5" overall width.

**Adjustable Straddle** with adjustable legs 21.5" to 36" inside width and 29" to 44" outside width.

**Counter-balance Straddle.** Get close to the load, 5" polyurethane rear swivel casters with brakes and 4" front wheels.

- Top of frame rollers facilitates laying truck horizontal for transport.



273510  
Fixed Base



273513  
Adjustable Straddle



273516  
Counter-balance Straddle

OVERALL DIMENSIONS

w: 24"	24"	29"	29"	29"	29"	29"	29"	29"
h: 68"	68"	79"	68"	68"	68"	68"	68"	68"
d: 35"	35"	43"	43"	43"	47"	47"	47"	47"

Part #	273510	273511	273512	273513	273514	273515	273516	273517
Model #	HWLFX-4	HWLFX-5	HWLSD-3.5	HWLSD-4	HWLSD-5	HWLCB-3.5	HWLCB-4	HWLCB-5
Capacity	400 lbs	500 lbs	350 lbs	400 lbs	500 lbs	350 lbs	400 lbs	500 lbs
Base	Fixed	Fixed	Adjustable Straddle	Adjustable Straddle	Adjustable Straddle	Counter-balance Straddle	Counter-balance Straddle	Counter-balance Straddle
Max. Lift Range	99"-120.5"	48.5"-71"	144"-165.5"	99"-120.5"	48.5"-71"	118.5"-140"	99"-120.5"	48.5"-71"
Lowered Height Range	3.5" / 27.5"	3.5" / 27.5"	2" / 25"	2" / 25"	2" / 25"	2" / 25"	2" / 25"	2" / 25"
Load Center	11.25"	11.25"	11.25"	11.25"	11.25"	11.25"	11.25"	11.25"
Weight	154 lbs	143 lbs	176 lbs	165 lbs	154 lbs	405 lbs	394 lbs	383 lbs

## Optional Removable Steel Platform

- Fits over forks.
- Size: 20.5"W x 24.25"L.
- Weight: 26 lbs.
- Part #273518

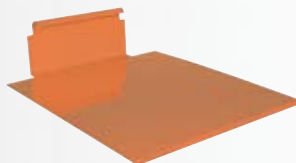

# Heavy Duty Narrow Aisle Shelf Cart

- Custom sizes available.
- Made in USA.
- Maneuvers easily in narrow spaces.
- Overall cart capacity 800 lbs. with evenly distributed loads.
- Four 3.5" TPR rubber locking swivel & two center rigid casters for better maneuverability.
- All welded construction.
- 2 & 3 shelf models available.
- Center caster tilting design provides greater maneuverability.
- Four shelf sizes standard:  
18" x 36", 18" x 48", 24" x 36", 24" x 48".
- 12 GA. steel shelves.



OVERALL DIMENSIONS

w: 19"	19"	19"	19"	25"	25"	25"	25"
h: 48.625"	48.625"	48.625"	48.625"	48.625"	48.625"	48.625"	48.625"
d: 49.75"	61.75"	49.75"	61.75"	49.75"	61.75"	49.75"	61.75"

Part #	260187	260188	260190	260191	260192	260193	260194	260195
Capacity	800 lbs	800 lbs	800 lbs	800 lbs	800 lbs	800 lbs	800 lbs	800 lbs
Shelf Size	18" x 36"	18" x 48"	18" x 36"	18" x 48"	24" x 36"	24" x 48"	24" x 36"	24" x 48"
No. of Shelves	2	2	3	3	2	2	3	3
Casters	4 Swivel 2 Rigid	4 Swivel 2 Rigid	4 Swivel 2 Rigid	4 Swivel 2 Rigid	4 Swivel 2 Rigid	4 Swivel 2 Rigid	4 Swivel 2 Rigid	4 Swivel 2 Rigid
Weight	97 lbs	116 lbs	125 lbs	154 lbs	121 lbs	146 lbs	158 lbs	196 lbs

# Battery Transfer Cart

- For use with a standard pallet truck (sold separately).
- Pallet trucks easily slides into 6.75" W x 3.5" H fork pockets.
- One person can easily remove and replace forklift batteries.
- (12) 2.25" diameter steel rollers.
- Swing tabs help to hold battery in place while on rollers.
- Winch with 2" wide nylon belt and safety latch hook.
- Height to top of rollers 6.5".
- Platform roller base: I.D. 26.75" W x 43.25" L.  
O.D. 27.25" W x 43.625" L.
- Adjustable winch height: Lowered - 29.625".  
Raised - 35.50".

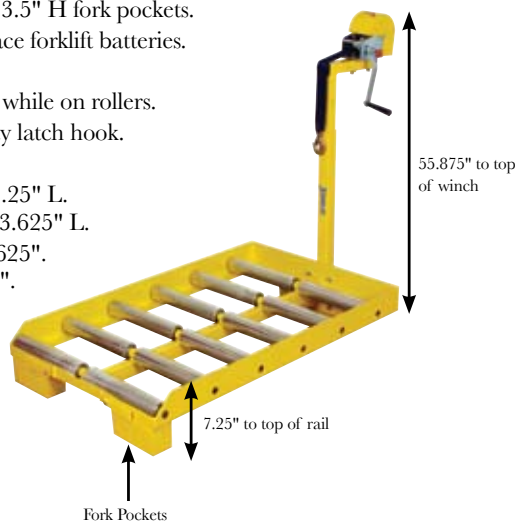

OVERALL DIMENSIONS

w:	27.25"
h:	41.50"
d:	55.875"

Part #	274260
Model #	BAT-TC
Capacity	4,000 lbs
W x L	26.75" W x 43.25" L (usable deck)
Weight	280 lbs

# Foldable Maintenance Platform

- Fork Pockets:  
7.75"W x 3.5"H.  
Centers: 26".
- Optional caster set #272572, 13.2 lbs.
- (4) swivel casters - 4" x 1.5" moldon polyurethane.



OVERALL DIMENSIONS

w:	37.5"
h:	81" w/o casters; 87.25" w/casters
d:	42.25"

Part #	272571
Capacity	600 lbs
Size	Platform Deck - 37" x 37" I.D.
Weight	220 lbs

# Power LiftKar HD

See the  
**LIFTKAR** video  
on our website!  
[www.wescomfg.com](http://www.wescomfg.com)



Part #274100 with optional fold-out wheel carriage - #274102



Optional 274103 snap-on toe plate with 4 dual swivel casters

Part #274100 with optional snap-on toe plate - #274103.

## Two Models

**Uni** – straight frame – accepts dolly option for 4-wheel support.

**Fold** – upper handle angle can be adjusted. Best for copiers, safes, heavy motors or any short and heavy load which would require the user to pull the load back to a very low position. The adjustable angle position on the Fold model allows the user to stand upright when using the truck at a very low angle.

■ Innovative edge-of-step braking system – automatically applies brake when wheels are at edge of step. Helps prevent loss of load control caused by accidental rolling down steps.

■ Brake can be shut off for use on level ground – prevents unwanted braking when moving over ground with an uneven surface.

■ Two operating modes: single step (ascend or descend button must be pressed after each step – ideal for maximum control), or continuous climb.

■ 24v quick-change battery pack – sealed maintenance-free battery.

■ Battery, charger and 137" x 2" cargo belt included.

■ 21" W x 7.25" D noseplate. Additional sizes available, contact Wesco Customer Service.

■ Two climbing speeds: 6 steps/min. or 10 steps/min.

■ Average number of steps with fully charged battery:

440 lbs. of cargo - 220 steps

550 lbs. of cargo - 190 steps

725 lbs. of cargo - 120 steps.

■ Maximum stair height 8.25".

■ 1 year warranty on parts against defects in materials and workmanship.

■ 6 month warranty on battery.

■ See website for available options.



725 lb. High Capacity Models

274101

### OVERALL DIMENSIONS

w: 21"  
h: 63"  
d: 19"

### OVERALL DIMENSIONS

w: 21"  
h: 47" - folded  
d: 19"

	274100	274101
Part #	274100	274101
Model	Universal	Fold
Capacity	725 lbs	725 lbs
Battery	Single	Single
Belt	2 piece with clasp - 10'	2 piece with clasp - 10'
Height	63" - straight frame	47" - folded
Weight	96 lbs	97 lbs

